

# **AGRO FlexFrame** **Flexible complete solution**

The BPW tandem running gear

we think transport



# we think transport

In the BPW Group, our aim is to provide our customers in the transport and logistics industry with the best possible support in their work. That is why an uncompromising orientation to your needs is of the utmost importance to us. This includes listening to you, ensuring that our solutions meet your individual requirements and being there for you in every situation. For us at BPW, this collaborative approach means: **we think transport**

In order to assist you in your transport activities, we have pooled the experience and industry know-how of BPW and its subsidiaries.

As an international mobility partner, we offer vehicle operators a perfectly coordinated product and service package. It helps you make your loading and transport processes transparent in order to structure them even more efficiently and safely and to simplify your fleet management.

With our telematics solutions for trucks and trailers, you always have all the relevant information and can take action when the need arises.

We will be pleased to support you right from the choice of the running gear to suit your particular needs, and will also provide assistance with financing and leasing in conjunction with our partner.

We know that the availability of your fleet is your number one priority. In this respect, you can rely on our worldwide service network: more than 3,200 service partners are ready to help. And to allow you to concentrate on your most important tasks, we offer you our maintenance contracts: they are cost-effective and can be tailored precisely to your needs.

If you would like to find out more, we will be pleased to share our knowledge with you. We offer seminars and training courses in your vicinity, too.

# 22 M20 bolts

join the running gear to the vehicle frame

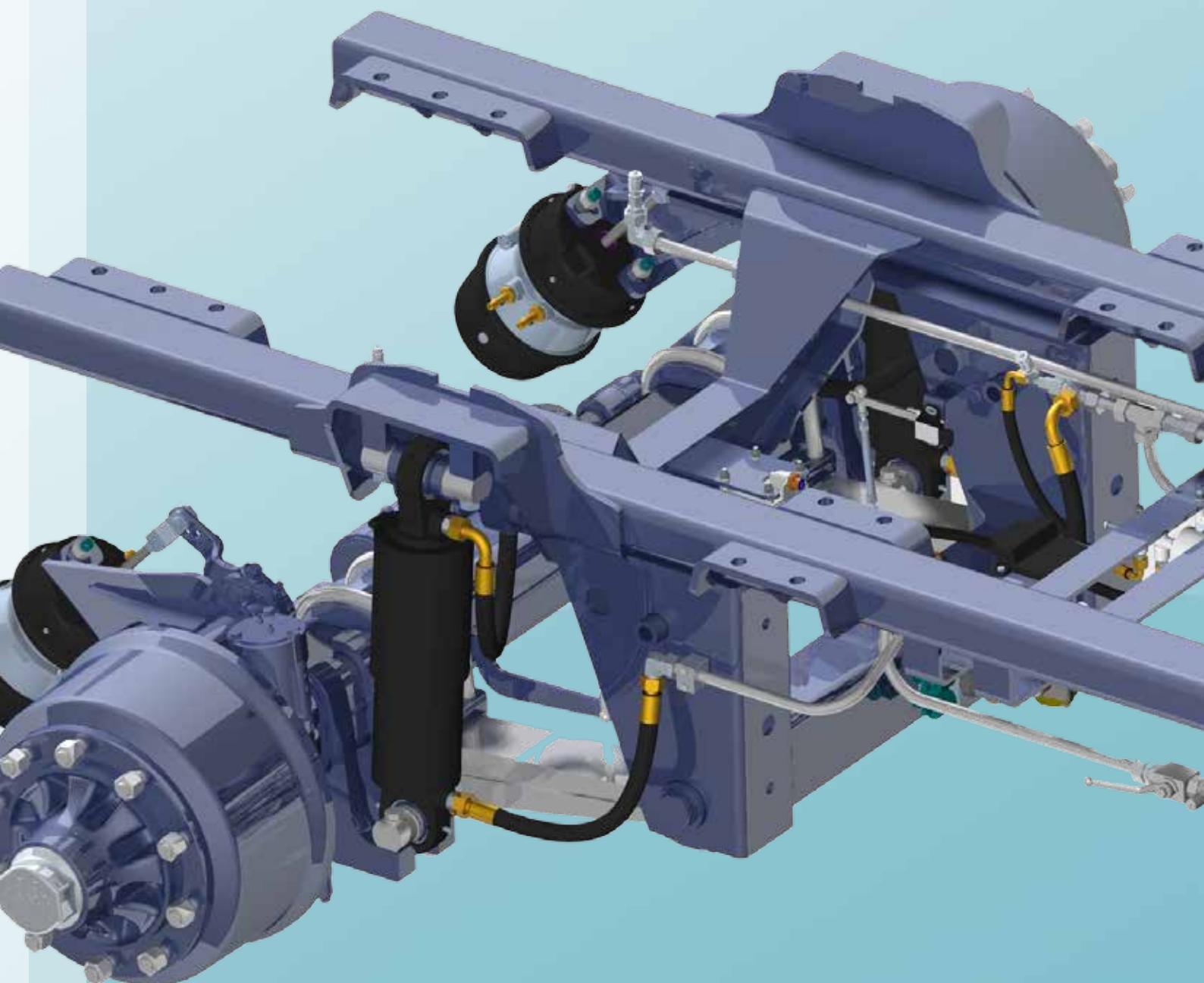

**8 hours less assembly time**  
up to 10% lower costs

# BPW AGRO FlexFrame

AGRO FlexFrame is BPW's solution in the area of tandem running gears. A concept for the modern agricultural vehicle producer. Axle loads with 2 x 12 tonnes at 40 km/h. A custom-designed frame. Parallel crossmembers for tippers and flatbed transporters, portal crossmembers for slurry tanks and silo transports.

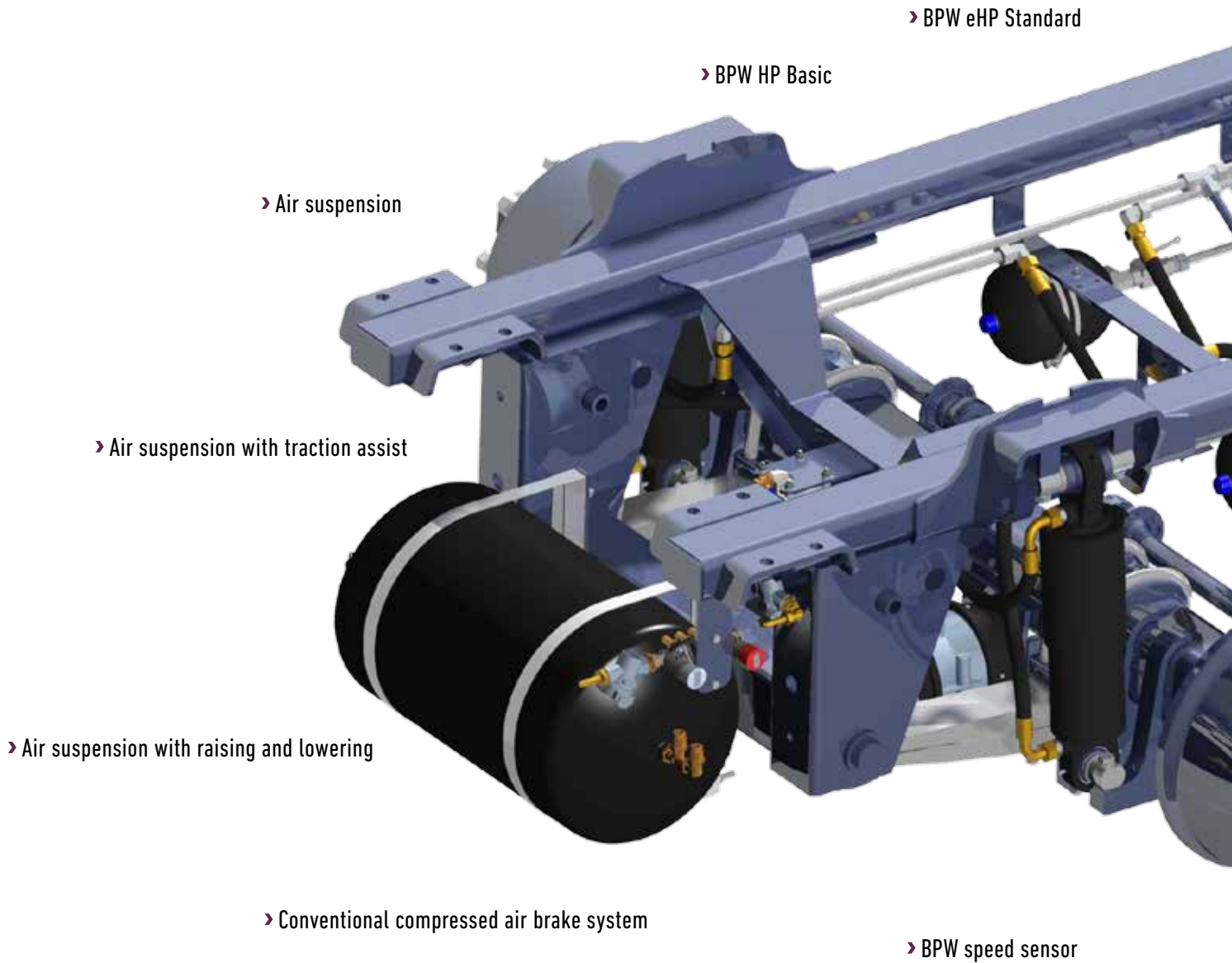

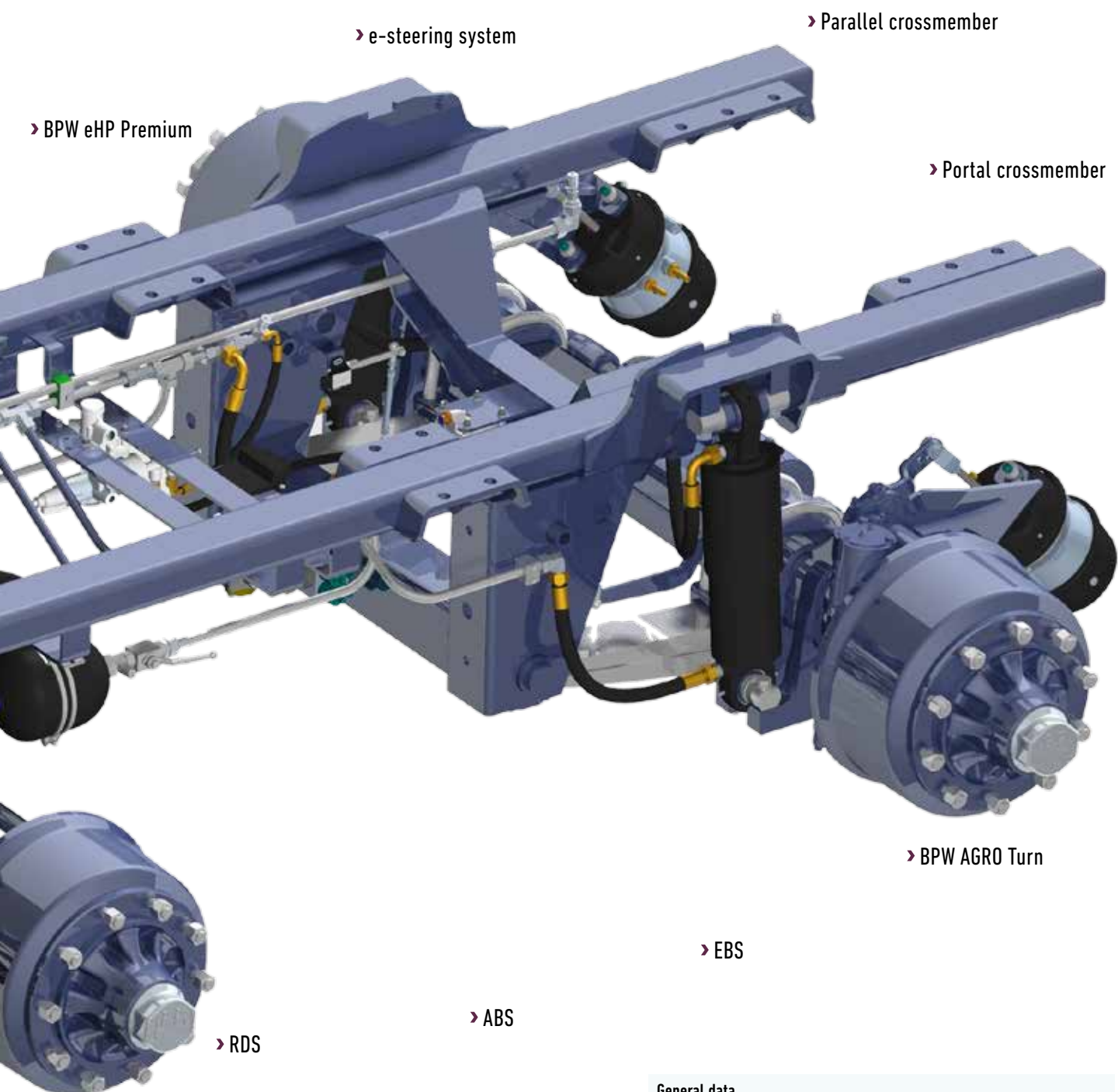

#### General data

- > 3 types of air suspension: standard, with traction assist or raising and lowering
- > 3 types of HP suspension: BPW Basic, BPW eHP Standard or Premium
- > Compressed air brake system: conventional, ABS, EBS
- > Ready for tyre pressure control system
- > BPW speed sensor
- > Ready for electronic hydraulic steering systems
- > Integrated steering angle sensor

# BPW AGRO FlexFrame

## High-end solution

The FlexFrame developed by BPW is a tandem running gear with 2 x 12 tonnes axle load at 40 km/h. Its special feature is the standardised concept for connection to the vehicle frame. The entire running gear is secured to the vehicle frame with 22 M20 bolts. Thanks to this complete system with many options, the delivery time is greatly reduced and the vehicle manufacturer gains greater flexibility. The possibilities are endless, from the choice of the suspension system to the fitting of the brake system all the way to the complete integration of a hydraulic steering system.

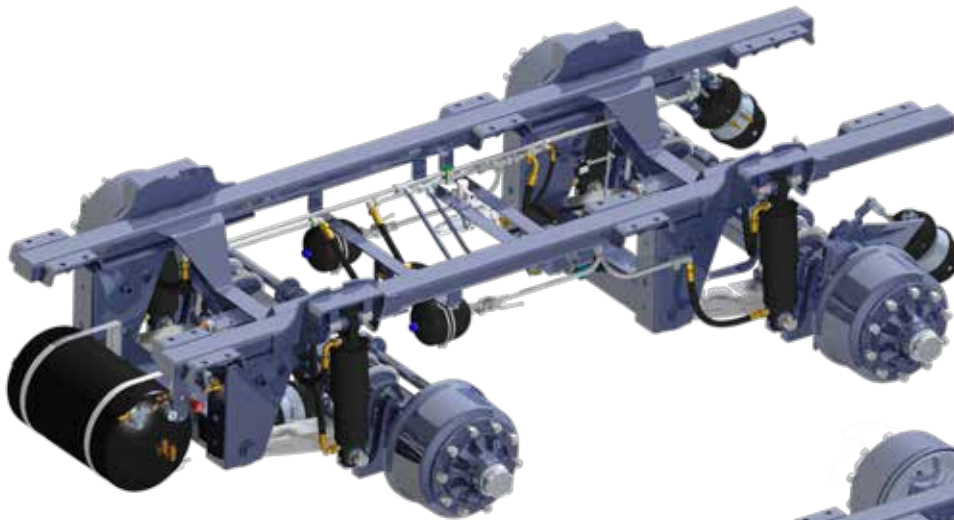

### Portal crossmembers

- › Optimised arrangement for slurry tanks



### Parallel crossmember

- › Optimised arrangement for tipper

#### Your benefits at a glance

- › Shorter and flexible delivery time
- › FMEA-certified frame construction
- › Documented threshold time measurement
- › Increased flexibility thanks to self-steering/positive steering
- › Modular system with standardised interface
- › Upgrade with components from premium partners
- › Parallel or portal design

#### Features and benefits

- › Flexible concept for air, hydropneumatic suspension
- › Individual series solution
- › Longer maintenance interval
- › Increased ground clearance

# BPW AGRO FlexFrame

## Standard with AGRO Turn



# 13,5 t axle load



### New high-tech concept:

A forged steering fork replaces the axle knuckle. The combination of steering fork and integrated spindle-knuckle replaces the steering housing with knuckle. Both steering fork and spindle-knuckle are forged and tempered.



### Mountable, adjustable brake chamber bracket:

The brake chamber bracket, which can be mounted in different positions, makes it easier for the customer to fit tyres of different sizes. An adjustable brake chamber bracket means more flexibility and greater ground clearance.



### Repositioned brake camshaft:

The position of the brake camshaft has been turned by 10° towards the rear. This opens up more space for an increased steering angle and gives adequate room for the suspension.



### Optimised steering pivot seals for durability:

The lubrication interval for the steering pivot bearing is increased significantly with the new steering pivot seal.



### New steering stop solution:

The stop for adjusting the steering angle is situated in an easily accessible position on the outer piston rod.



### New brake camshaft bearing:

The new brake camshaft bearing is located in a tube to protect it from dirt.

The BPW Group:



Flyer AGRO FlexFrame 16981501e

