

**355** GROWING TOGETHER. ALL YEAR LONG.



## Harvest

It doesn't matter if you use round or square balers, globally BPW offers the matching products for the demands of our customers on running gears. With many different product benefits, the pendulum axle and bogie suspension units are the perfect solution for every baling press.

The brands of the BPW Group:



we think transport



# Harvest

## Benefits that convince

- Asymmetrical pendulum structure for easier ground adjustment
- Ideal balance for severe off-road applications
- Constant braking effect for the highest safety
- Simple vehicle homologation due to optimum brake overload and EU-regulatory-compliant brakes
- Steering axle with thrust washer for safe self steering
- Frame protection thanks to side-independent compensation
- High service life of the wearing parts

## THE BPW EFFECT

100 %

customized production

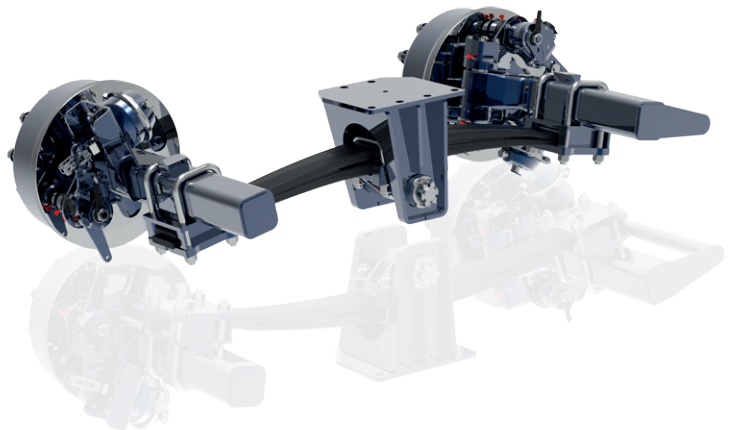
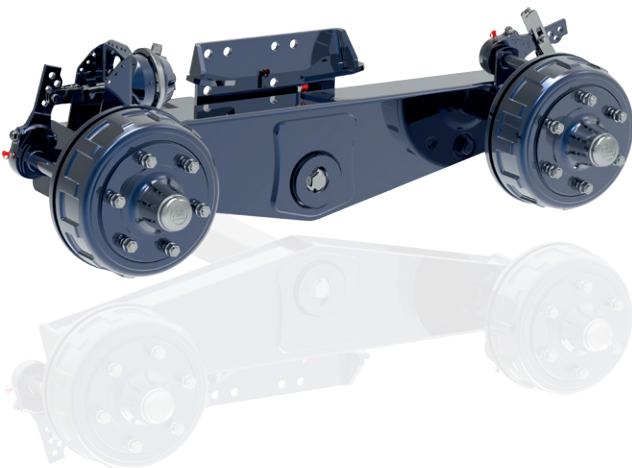

## Technical data - Pendulum axle unit

- 70 mm axle beam / brake N 310x80
- GS 5506 Bearing – 6.5 tonnes
- Asymmetrical pendulum with 1100 mm wheelbase
- 100 mm middle axle beam
- 12" Diaphragm cylinder
- Manual slack adjuster

## Technical data - Bogie axle unit

- Rigid and steered axle
- 110x14 mm axle beam / brake N 400x120
- GS 9010 Bearing – 14 tonnes
- Asymmetrical parabolic springs with 1340 mm wheelbase
- Automatic slack adjuster
- 16" Diaphragm cylinder